

ART. 2036

Kurek kulowy z zanizonym przelotem, kolnierzowy 1 piece reduced bore ball valve flanged ends.

Charakterystyka

1. Jednoczesciowy calospawalny kurek z zaniz. przelotem.
2. Kolnierze wg normy DIN 2501.
3. Konstrukcja ze stali węglowej DIN St-37.
4. Uszczelnienie kuli PTFE + Grafito.
5. Uszczelnienie trzpienia - Viton.
6. Kula nierdzewna AISI 304, Trzpień AISI 303.
7. Maksymalne ciśnienie robocze: PN 16/40 zal. od srednicy
8. Temperatura pracy -30 °C +200 °C.
9. Gotowy do pracy bezobsługowej.
10. Łatwy w instalacji.

Features

1. One piece reduced bore ball valve.
2. Flange ends according to Std. DIN 2501.
3. Made of Carbon Steel DIN St - 37.
4. Ball seat PTFE + Graphite.
5. Stem O'rings made of FPM (Viton).
6. Ball in SS 304 and Stem in SS 303.
7. Max. working pressure PN 16/40 according to size.
8. Working temperature -30 °C +200 °C.
9. Free of maintenance, adjustment or lubrication.
10. Easy instalation.

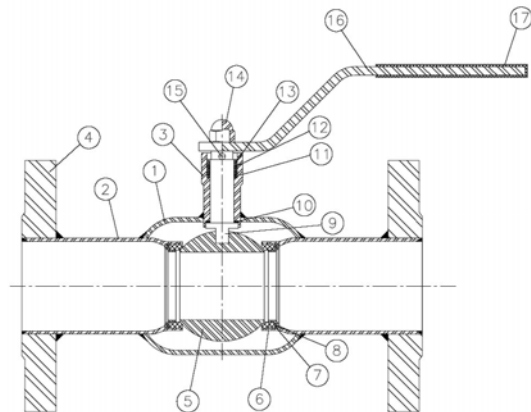

N°	Nazwa / Name	Material	Powloka /Surface
1	Korpus / Body	Stal węglowa / Carbon Steel DIN St-37	Malowana / Painted
2	Rura / Extension Pipes	Stal węglowa / Carbon Steel DIN St-37	Malowana / Painted
3	Kominek / Stem Bush	Stal węglowa / Carbon Steel DIN St-37	Malowana/ Painted
4	Kolnierz / Flange	Stal węglowa / Carbon Steel	Malowana / Painted
5	Kula / Ball	AISI 304	-----
6	Uszczelnienie kuli / Seat ball	PTFE + Graphite	-----
7	Gniazdo uszczelnienia kuli / Seat Bush	Stal nierdzewna / Stainless Steel	-----
8	Podkładka sprężysta / Spring Washer	AISI 301	-----
9	Trzpień / Stem	AISI 303	-----
10	Uszczelka / Trust Washer	PTFE	-----
11	Uszczelka / Trust Washer	PTFE	-----
12	O-ring / O'ring	FPM (Viton)	-----
13	Podkładka / Stem Ring	Stal węglowa / Carbon Steel	O cynk / Zinc-Plated
14	Nakretka / Nut	Stal węglowa / Carbon Steel	O cynk / Zinc-Plated
15	Ogranicznik / Stopper	Stal węglowa / Carbon Steel	O cynk / Zinc-Plated
16	Raczka / Handle	Stal węglowa / Carbon Steel	O cynk / Zinc-Plated
17	Powloka rączki / Handle Sleeve	Vynil	-----

WYMIARY GLOWNE / GENERAL DIMENSIONS

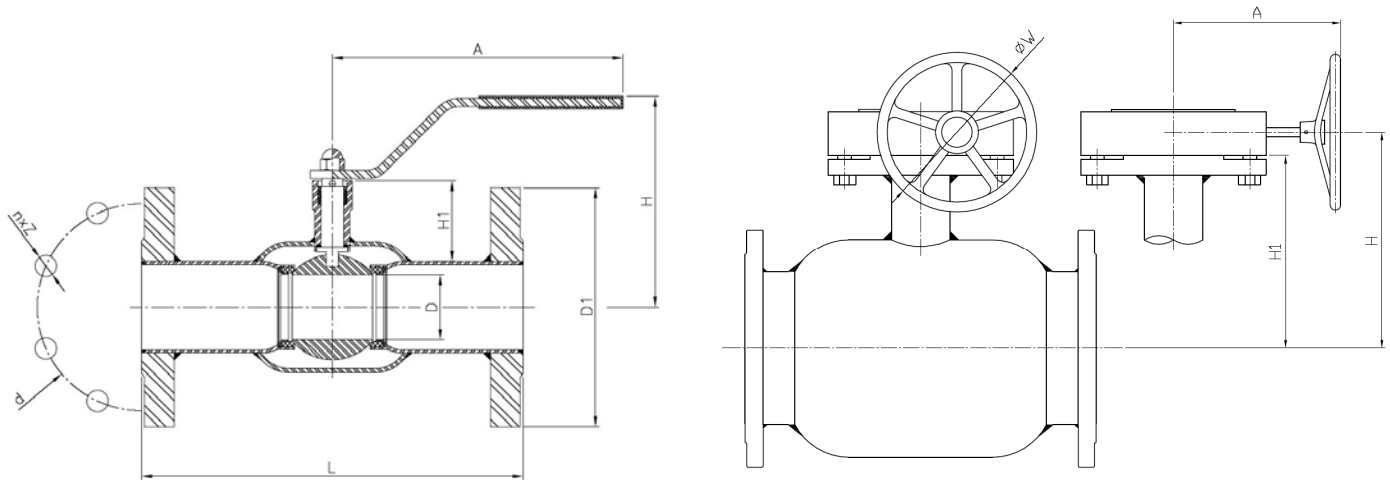

Ref	DN	PN	D	D1	n x Z	d	H	H1	A	ϕW	L	Waga / Weight (kg)
2036 04	1/2"	40	10	95	4 x 14	65	100	40	120	***	130	1,8
2036 05	3/4"	40	15	105	4 x 14	75	100	40	120	***	150	2,4
2036 06	1"	40	20	115	4 x 14	85	105	40	150	***	160	2,9
2036 07	1 1/4"	40	25	140	4 x 18	100	105	39	150	***	180	4,7
2036 08	1 1/2"	40	32	150	4 x 18	110	125	59	190	***	200	5,4
2036 09	2"	40	40	165	4 x 18	125	130	59	190	***	230	7,2
2036 10	2 1/2"	16	50	185	4 x 18	145	180	71	280	***	270	9,7
2036 11	3"	16	65	200	8 x 18	160	190	77	280	***	280	11,5
2036 12	4"	16	80	220	8 x 18	180	220	92	280	***	300	16,8
2036 13	5"	16	100	250	8 x 18	210	245	95	420	***	325	23,6
2036 14	6"	16	125	285	8 x 23	240	265	103	550	***	350	32,0
2036 16	8"	16	150	340	12 x 23	295	270	115	254	300	400	56,0
2036 18	10"	16	200	405	12 x 27	355	303	111	254	400	530	111,0
2036 20	12"	16	250	460	12 x 27	410	369	155	342	400	630	191,0

Uwaga: od DN200 do DN300 kurki z przekładnia ślimakowa.
Remark: 8" - 10" - 12" with Gear Operator.

ZAKRES PRACY WG TEMPERATURY I CISNIENIA

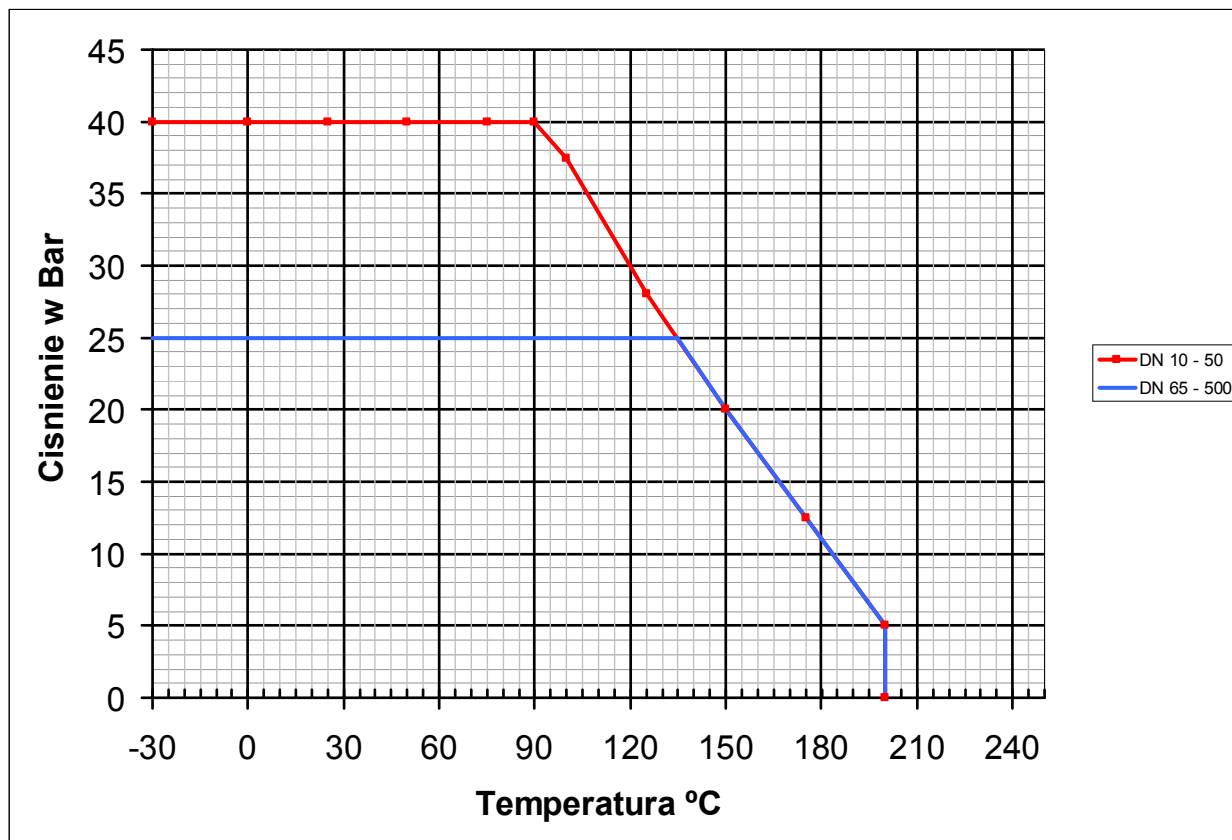

WARTOSCI Kv / Kv VALUES

Kv = Współczynnik przepływu wody przez zawór w m³ na godzinę.

Kv = The rate of flow of water in cubic meter per hour that will generate a pressure drop of 1 bar across the valve.

DN	15	20	25	32	40	50	65	80	100	125	150	200	250	300
Kv	8	15	24	40	66	104	180	300	450	780	1100	1550	2900	4450